

# SEME SOLAR BOOM GATES

LV Solar boom gates

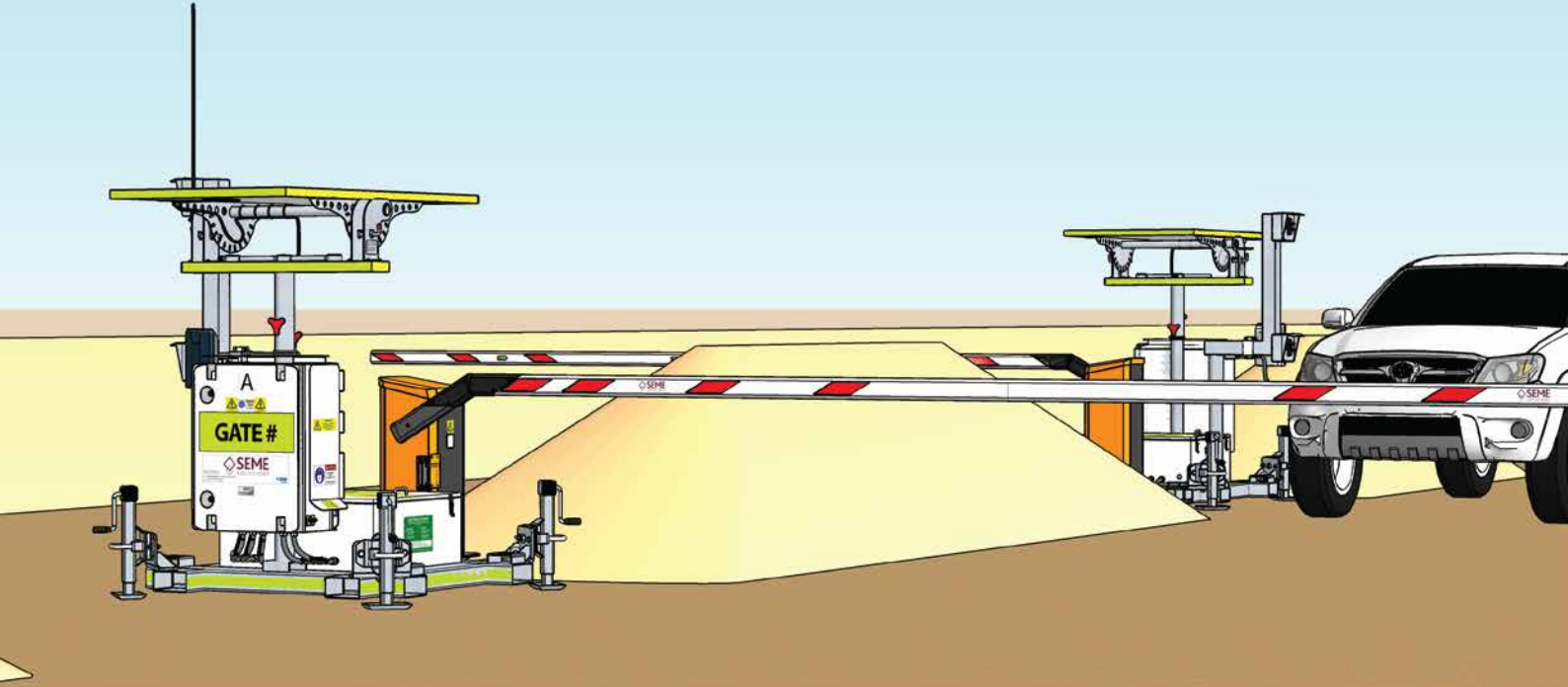

A member of the  
SCEE GROUP



## Mobility, flexibility & durability

SEME LV Solar Boom gates are designed to be able to be deployed rapidly without relying on existing infrastructure to provide a versatile solution for sites which have frequently changing access control requirements. With excellent efficiency & autonomy, these units will continue to operate without sunlight for several days whilst providing hundreds of operations per day. They are installed in some of the harshest conditions Australia has to offer and continue to operate reliably year on year. These units are able to interface to most every access control system and can also operate in a stand alone function.

## Unprecedented reliability

For entrances to mining, freight forwarders, company and port facilities, as well as on multi-lane roads – SEME LV Solar Booms barriers are the ideal solution when entrances of up to 6M have to be controlled with a single barrier. These systems feature a low maintenance, long service life MHTM drive that is designed for over 10 million opening and closing cycles. As standard the system relies on industry leading, time proven Gallagher access control equipment that provides excellent non proprietary features and reliability. The units can provide lengthy off-line operation without reliance on client networks whilst retaining half a million events and all cardholder information.



**Cost Saving, Flexible & Versatile**  
When your operations change, SEME Solar gates are ready, there is no need to wait for costly & lengthy infrastructure roll-outs to your desired location.



**Certified**  
SEME Solar Gates have been electrically and structurally certified to stringent RPEQ standards and have been manufactured to ISO9001, ISO14001 & ISO45001 standards.



**Wireless**  
4G and LTE ready, we can tailor these units to your access control system so you can deploy these units wherever they are needed. They can even be configured as stand alone.



**Low Maintenance**  
The MHTM™ drive unit is maintenance-free energy efficient & quiet. The high torque guarantees best possible operation even under extreme weather conditions.



ACCESS

SECURITY

CCTV

SAFETY

# SEME SOLAR BOOM GATES

## LV Solar boom gates

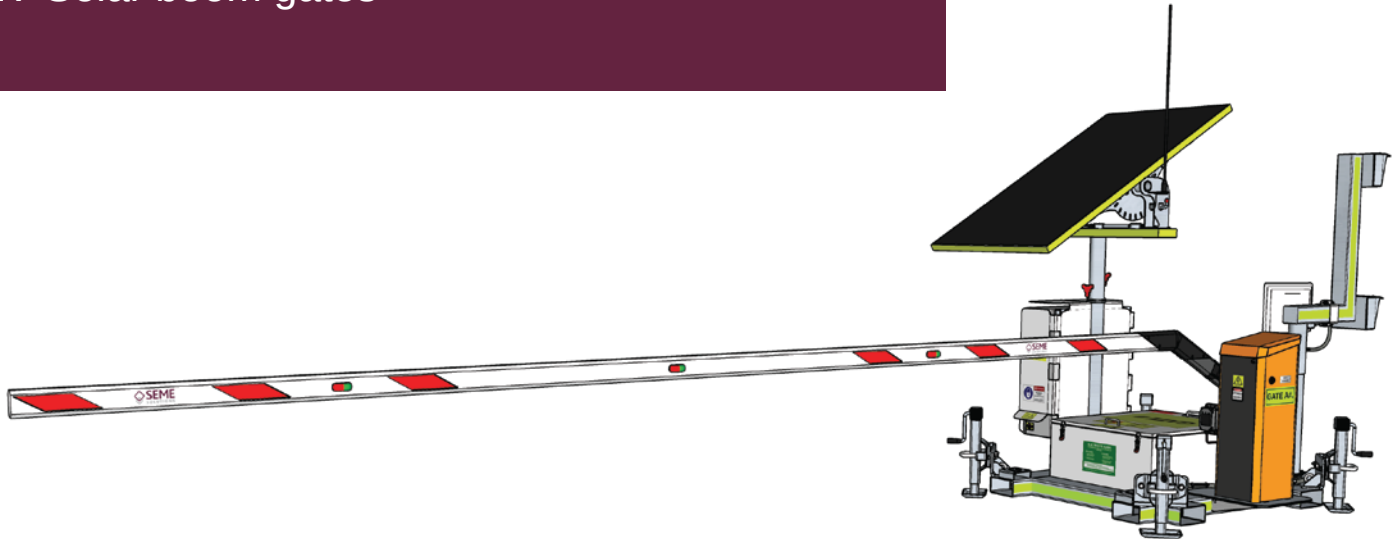

- > Low operational costs
- > Option for full wireless operation
- > Low maintenance
- > Deployable In under an hour
- > Customizable
- > Continued operation independent of client network
- > Robust
- > Tested to conditions
- > Easy setup
- > Designed for 10 million lifetime operations

### Technical data

Lane width	Max. 6 m	(3m-10m available)
Opening/closing time	4.0 s	
Card Reader Range	max. 10 m*	
Operational Autonomy (without sunlight)	5 Days @ 900 operations per day	
Drive technology	MHTM™	
Voltage	24VDC	
Installed battery capacity	330Ah 4x165Ah AGM installed in series/parallel installed in dual skin vented cabinet	
Installed Solar Panel	1 x 340W LG-340N1C-A5 LG NeON® 2 Module Cells: 6 x 10 Module efficiency 19.6%	
System connectivity	4G, 5G, LTE, PTP WiFi	
Access control system compatibility	All access control systems supported & system capable of operating stand-alone	
Card reader compatibility	All card reader technology compatible	
Obstruction Sensor Technology	Banner Radar Sensor	
Wind Rating	Structurally certified to extreme wind events (120kph+) when deployed in operational configuration	
Duty cycle	100 %	
Skid Construction	Galvanized Steel	
Dimensions (W x D x H)	1750mm x 1800mm x 2740mm (without arm, in transport position)	
Enclosure rating	IP 66	
Temperature range*	-10 to +55 °C	
Weight	630 kg	

\*using optional long range reader



ACCESS

SECURITY

CCTV

SAFETY

## Features

Gallagher 6000 Controller as standard access control system	✓
Banner Radar Sensor for vehicle detection as standard	✓
Units will continue operating in event of client network outages	✓
Offline event retention - 500,000 events	✓
No Interconnection cabling required	✓
Custom identification labeling	✓
Internal and external lighting	✓
Lighting along length of boom arm indicating operation	✓
Selectable opening and closing speed	✓
Customizable stay open time 10 - 60s	✓
Fail safe or fail secure operation	✓
Purpose built skid	✓
Adjustable leveling feet	✓
Manual Override for large loads	✓
Lockable single operation 4 Pole Solar & Battery Isolator	✓
Crane & Forklift points	✓
Structural and electrical engineering certification	✓
4 Equipment mounting hard-points on skid	✓
Bluetooth connectivity for power and battery monitoring	✓
Australian designed & constructed	✓

## Options

Special colours and coatings	✓
Nedap TRANSIT Ultimate long range reader (10M Read Range)	✓
Additional hard-point attachments (such as weather monitoring)	✓
Key switch operation	✓
Non standard access controller integration	✓
CCTV cameras	✓
GPS Location	✓
Web interface for monitoring solar & battery power performance	✓
Full Materials Data Register (MDR)	✓
Full engineering package	✓
On site setup & training	✓
Larger battery banks	✓
Maintenance plans	✓
Other custom requirements met upon request	✓

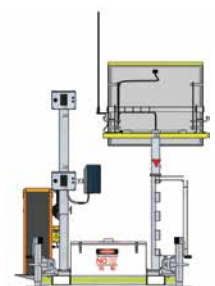
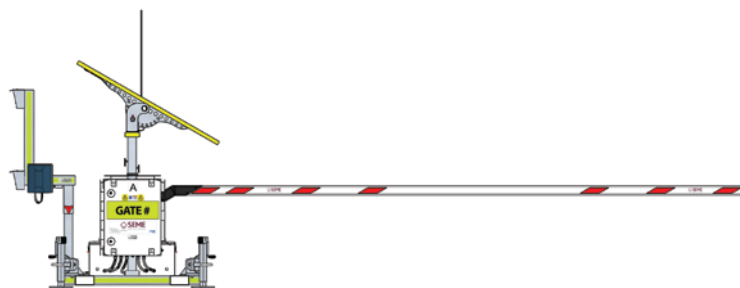

ACCESS

SECURITY

CCTV

SAFETY

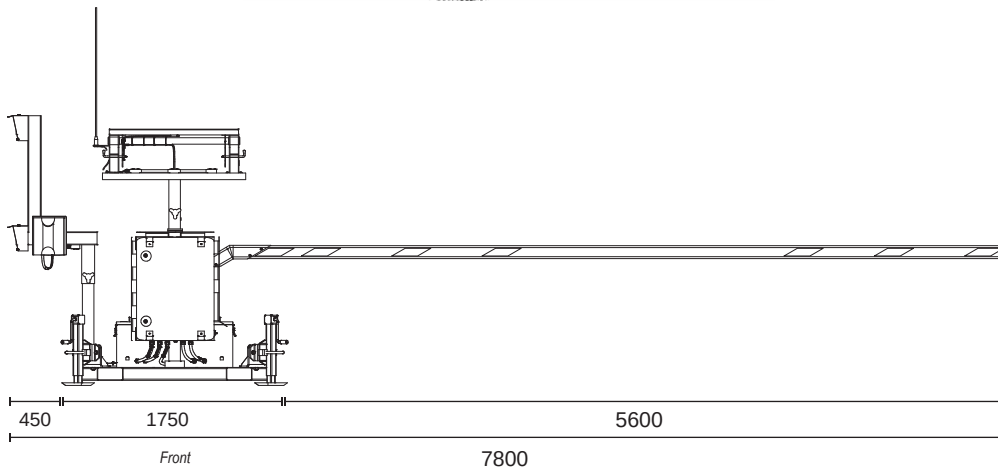
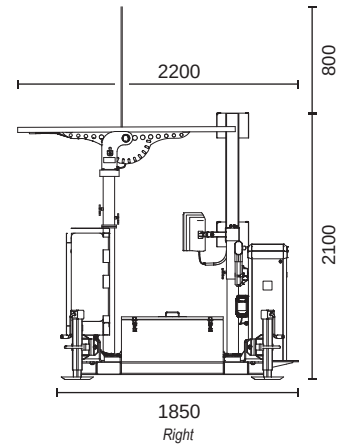
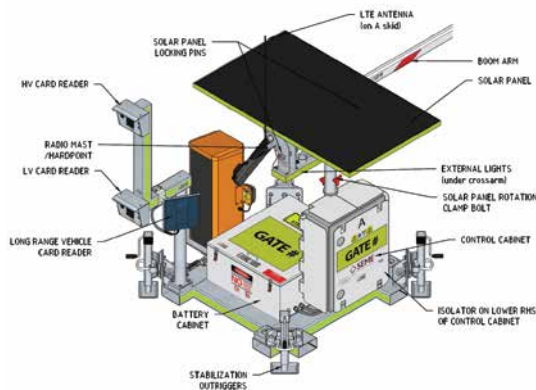
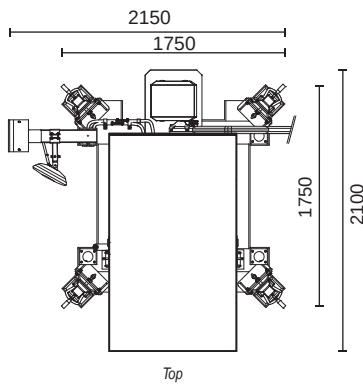
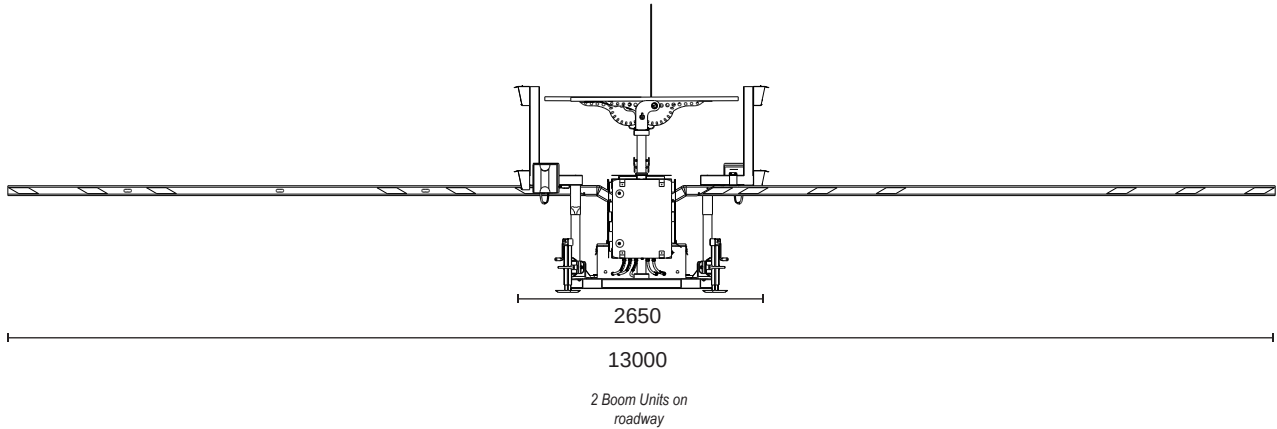

all dimension in mm unless otherwise stated

## FOR MORE INFORMATION

Call our one of our experienced Sales Team. They welcome any opportunity to field any questions you may have

1300 00 SEME (7363)

Level 15, 225 St Georges Terrace, Perth WA 6000  
PO Box 7977 Cloisters Square PO WA 6850

P 08 9204 7200  
F 08 9204 7240  
E sales@seme.com.au

ABN 67 131 507 152  
EC 1631  
SA 57973



SEME Solutions are one of Australia's leading service provider of electronic security solutions & have been for over 50 years. Specializing in the Integration (installation and maintenance) of CCTV, Access Control, Intruder, Fire Detection, Nurse Call and Duress Systems.

SEME Solutions have the capability, and proven track record, to deliver high-end projects and have a proven track record of quality control, safety and service delivery Australia wide.

The team at SEME Solutions are amongst the most skilled security system integrators in the country. Our teams have proven experience integrating not only a wide range of market leading products but also working with businesses that require the integration of new technology with existing legacy products and systems. Whatever solution your security challenges require – we have the expertise and resources to solve it.



ACCESS

SECURITY

CCTV

SAFETY