

# SEME Portable Reader



A member of the  
SCEE GROUP



## Mobility, flexibility & durability

The SEME portable reader is a mobile card reader used extensively in the mining industry as a mobile attendance/fatigue management logging point. Its design allows it to operate in harsh environments where electrical and communication connections are not possible such as buses, remote locations and gate houses.

The reader is designed to operate over the Gallagher (Cardax) Security Management Platform. The Lithium Iron Phosphate battery remains charged for up to 12+ hours allowing the unit to be carried to where it is needed and used extensively before needing to be returned to charge.



### Cost Saving, Flexible & Versatile

When your operations change, SEME Portable readers are ready, there is no need to wait for costly & lengthy infrastructure roll-outs to your desired location.



### Scalable

Designed to help you minimise downtime when you need to expand operations and maintenance activity, multiple units can be deployed to a single site.



### Robust

Based on the sturdy Pelican 1400 case, these units will endure poor treatment in some of the harshest environments in world.



### Multi Purpose

Whether required for mustering, onsite/offsite, random drug and alcohol, fatigue management. These units are easily configurable and transferable between departments



ACCESS

SECURITY

CCTV

SAFETY

## Technical data

Access control system compatibility	All access control systems supported & system capable of operating stand-alone	
Card reader compatibility	All card reader technology compatible	
Card Reader Range	8cm standard	
System connectivity	4G, 5G, LTE, PTP WiFi	
Voltage	24VDC <i>12VDC available on request</i>	
Installed battery capacity	7aH Lithium Ferro-Phosphate (LiFe-Po)	
Battery Life	12 Hours continuous use	
Construction	Polypropylene	
Dimensions (W x D x H)	339mm x 295mm x 152mm (Pelican 1400 Case)	
Environmental rating	IP 67	
Temperature range*	Operating Temperature -20°C to 65°C	Storage Temperature -45°C to +70°C
Weight	5 kg	

## Features

Water dust & crushproof case	✓
Units will continue operating in event of client network outages	✓
Automatic synchronization with Command Center database when 3G signal is available.	✓
Built in Sierra RV50x 4G modem to utilize 4G, 5G, LTE, PTP WiFi	✓
Network Plug for Manual connection of device to network in the case of 4G network failure.	✓
High charge rate providing 10hours of operation with 1 hour charge.	✓
Vehicle charger (cigarette type connector)	✓
Offline event retention - 500,000 events	✓
No Interconnection cabling required	✓
Gallagher 6000 Controller as standard access control system	✓
AC Charger	✓
LED and Buzzer to provide audible and visual indication of Valid Cardholder Sync.	✓
Controller online LED for the bus driver to confirm system online	✓
Charge Indication LED's to provide charge levels	✓
Remote Reader and indication model allowing for permanent installation	✓
Australian designed & constructed	✓

## Options

Custom identification labeling	✓
Non standard access controller integration	✓
Options for a bus mount kit	✓
GPS Location	✓
On site setup & training	✓
Maintenance plans	✓
Other custom requirements met upon request	✓

- > Low operational costs
- > Full wireless operation, no interconnecting cables
- > Low maintenance
- > Customizable
- > Continued operation independent of client network
- > Robust
- > Tested to conditions
- > Easy setup



ACCESS

SECURITY

CCTV

SAFETY

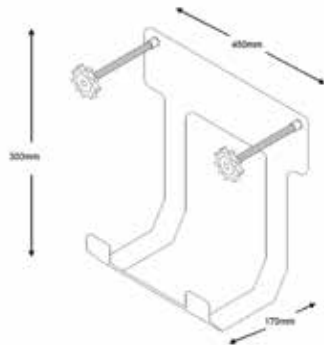

Optional Bus Mounting Kit

## FOR MORE INFORMATION

Call our one of our experienced Sales Team. They welcome any opportunity to field any questions you may have

1300 00 SEME (7363)

Level 15, 225 St Georges Terrace, Perth WA 6000  
PO Box 7977 Cloisters Square PO WA 6850

P 08 9204 7200  
F 08 9204 7240  
E sales@seme.com.au

ABN 67 131 507 152  
EC 1631  
SA 57973



SEME Solutions are one of Australia's leading service provider of electronic security solutions & have been for over 50 years. Specializing in the Integration (installation and maintenance) of CCTV, Access Control, Intruder, Fire Detection, Nurse Call and Duress Systems.

SEME Solutions have the capability, and proven track record, to deliver high-end projects and have a proven track record of quality control, safety and service delivery Australia wide.

The team at SEME Solutions are amongst the most skilled security system integrators in the country. Our teams have proven experience integrating not only a wide range of market leading products but also working with businesses that require the integration of new technology with existing legacy products and systems. Whatever solution your security challenges require – we have the expertise and resources to solve it.

